

WHAT IF
EVERYTHING
WERE **THIS**
EASY?

CEMB 2-hit



CEMB

2-hit



INNOVATION WITH SIMPLICITY



INNOVATIVE

The operator, by following simple on-screen instructions, manually moves the wheel to activate the movement of the **LASER SPOTTER** on the rim and acquire its dimensions. Once the dimensions are acquired, a light punch on the tyre transmits the input to the software to store the information, thus making the process extremely simple and immediate. At this point, it is possible to carry out the unbalance measurement spin.



STURDY

2-hit, since it no longer uses the automatic gauge, eliminates the need for periodic maintenance typical of mechanical devices, traditionally more subject to wear, all to the advantage of greater durability.



EASY TO USE

2-hit uses a unique system which, with the aid of a **LASER SPOTTER** and a line laser, allows both to acquire the wheel dimensions with extraordinary simplicity and precision, and to indicate the correct position for correcting the unbalance.



ERGONOMICS

With the **2-hit**, CEMB extends the range of **ERGOFAST** products by maximizing the concept of ergonomics. Since there is no gauge, the operator is no longer forced to assume awkward postures to acquire dimensions, but has the ability to work in an upright position, reducing physical effort and increasing performance and efficiency.



QUICK

The balancing process has never been so **FAST, SIMPLE AND ACCURATE!**

Wheel dimensions acquisition



Confirmation of each dimension



Measurement spin start



2-hit is the result of an innovative project that transforms the wheel balancing process, thanks to the perfect mix of speed, ease of use, strength and ergonomics. A professional product, but so intuitive that it can be used by anyone.



CEMB PATENT PENDING

- **LASER SPOTTER** - Unique tool that allows selecting the correction planes with maximum accuracy and then precisely indicates the exact point of application of the weights
- **LASER MATCHING** - Line laser emitter which, together with the laser spotter, allows calculating the diameter of the rim
- **OPB One Plane Balancing** - Correction of both static and dynamic unbalance on one plane at once and with only one weight
- **AutoAdaptive Mode** - The new tolerance calculation system
- **LA Sonar** for automatic measurement of the wheel width **CEMB PATENT**
- **ALU-S Balancing mode** - Adhesive weights on the internal rim planes with specific counterweight position indicator
- **EMS Sonar (option)** - 1st Harmonic and Peak to Peak) Automatic and quick eccentricity measurement during the normal balancing cycle
- **HubMatch** - During the measuring cycle, the wheel's "maximum eccentricity point" is detected and displayed on monitor, therefore allowing for its reduction during the re-mounting of wheel on vehicle (only with EMS Sonar)
- **Tire Set** - The software indicates the best wheel positioning on the vehicle to get the best ride (conicity) and to minimize wheel vibrations (eccentricity) (option available only with EMS sonar)
- **Pneumatic wheel locking** **CEMB PATENT**
Floor to floor time reduction / Extremely easy and quick to use / Very accurate wheel centering
- **Automatic positioning and locking** of the wheel in weight position

WHAT IF EVERYTHING WERE **THIS EASY?**

STANDARD ACCESSORIES

In 1952 Cemb created the cone adapters for balancing machines and since then the company continued developing and producing high precision centering systems for any type of wheel. **CEMB DOES NOT RECOMMEND THE USE OF NON-ORIGINAL ADAPTERS ON ITS BALANCING MACHINES.**

UC20/SE2

composed of: SE KIT,
3 CONES KIT and
WDC GAUGE



PNEUMATIC
LOCKING



SE KIT - 41FF034417

(ring, quick locking sleeve
SE2, SE spacer)



3 CONES KIT - 41FF034416

Ø 45÷110 mm, pincer-hammer and
60 g. counterweight



WIDTH GAUGE 46FC77653

Wheels with special dimensions, geometry and centering may require the use of special flanges that CEMB supplies as an option, to better meet the needs of the market. **For more information see the complete brochure on the web site: www.cemb-usa.com**



Zero Weight Lift

OPTION TO REDUCE ANY EFFORT

- **PERFECT CENTERING** Wheel automatic lifting. Ideal centering and more accurate balancing
- **QUICK** Quicker than any other traditional lift. A single pedal controls the whole working cycle
- **AUTOMATIC** Electronic system with PLC
- **UNIVERSAL** Applicable to any CEMB balancing machine

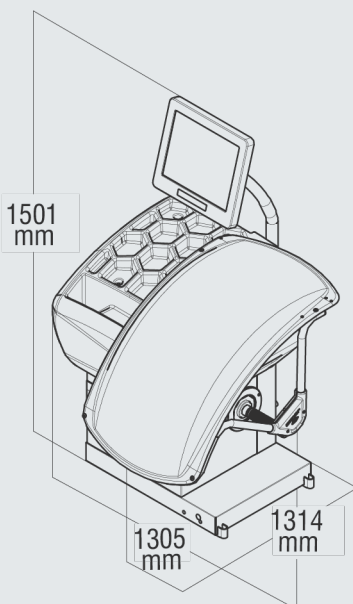

Power Supply

Wheel Clamping Type

Max. Rim Diameter

Max. Rim Width

Max. Tire Diameter

Max. Wheel Weight

Machine Weight:

220V, 1ph

Pneumatic

30" (765 mm)

20" (510 mm)

42" (1066 mm)

165 lbs. (75 kg)

264 lbs. (120 kg)



CEMB

BALANCING MACHINES

CEMB S.p.A.

Via Risorgimento, 9 23826 Mandello
del Lario (LC) - Italy www.cemb.com



Garage equipment division

CEMB - ITALY

Plant and Training Center

Phone +39 0341 706111

garage@cemb.com

CEMB USA - BL Systems Inc.

2873 Ramsey Road

Gainesville, GA 30501 - USA

Phone +001 678 717 1050

Fax +001 678 717 1056

sales@cemb-usa.com



All the data and features mentioned in this catalogue are purely for information and do not constitute any commitment on the part of our company, which reserves the right to make any and all alterations it may consider suitable without notice.