

DWA 1100



ENGINEERED IN ITALY
MADE FOR THE USA

**8-CCD WHEEL
ALIGNMENT
FOR CAR AND
LIGHT TRUCK**



CEMB

DWA 1100

LITHIUM BATTERIES: 24 hours of work, 1 year guaranteed

FEATHERWEIGHT SENSORS : only 2.6 kg Immediate connection with innovative **BT² wireless communication**

SILICON ACCELEROMETER: shock-proof

DIRECT RECHARGE OF SENSORS: no need to disassemble them

Designed to fit also SUV tires: **NO EXTENSIONS REQUIRED**

Truck and bus wheel alignment **AVAILABLE WITH SMALL EXTRA CHARGE**

SUNLIGHT FILTER: over 12 m wheelbase even in outdoor sun exposed environment

Simple and **user-friendly software**

SOFTWARE



FAST caster swing



Adjust two axles in one screen

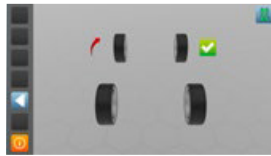

Direct spoiler, no extensions required

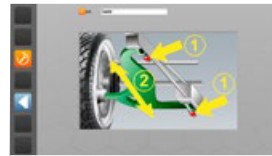

Clear help for adjustment



AUDIT function for the identification of driving problems

DWA1100 (with cabinet)

Ergonomic design

Industrial computer

No moving parts more likely to break

Data update through USB



STANDARD CONFIGURATION

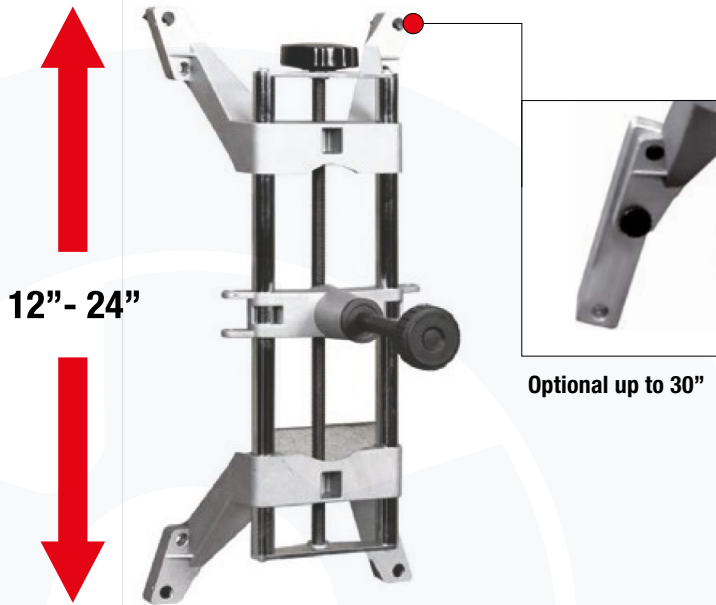

12"- 24"

Optional up to 30"



Metal 80 mm grips for 4-WD, SUV, light trucks and rims with hubcap



Metal 48 mm grips with reference surface to optimize runout

OPTIONAL ACCESSORIES

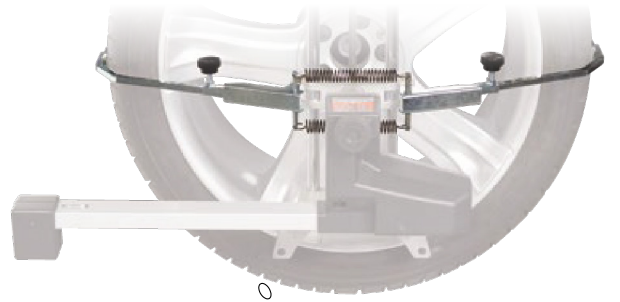

Clamp supporting arms and set of tips for tyres with external diameter up to 31" (with optional support arms up to 40")

Grips for all rims and tyres are available



Metal grips for clamping on steel rims from the inside

STANDARD COMPOSITION

Computer with WINDOWS operating system, 27" TFT monitor, colour printer, USB keyboard, mouse (only for DWA1100) 4 car sensors

clamps + safety elastic band + 2 set of grips
mechanical turntables for cars

Steering lock + Brake pedal lock

Wheel alignment software and database for CARS

OPTIONS



Premium turntables: capacity 1000 kg per plate, Ø 35 cm, with rubber supports



WiFi connection for automatic software updates



Truck and Bus upgrade kit

TECHNICAL DATA

PACKAGE DIMENSIONS AND GROSS WEIGHT:

113x113x113 cm (44,5x44,5x44,5") 220 Kg

Net weight: 155 Kg

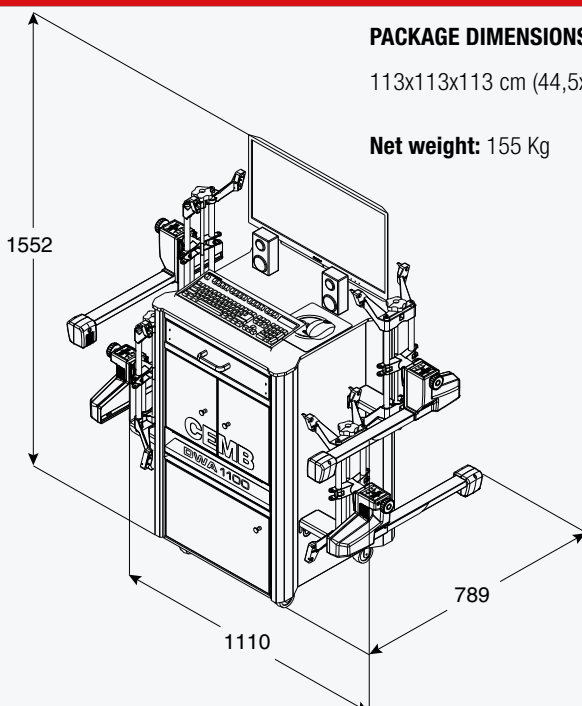

CEMB USA - BL Systems Inc.
2873 Ramsey Road
Gainesville, GA 30501 - USA
Phone +001 678 717 1050
Fax +001 678 717 1056
sales@cemb-usa.com
www.cemb-USA.com



CEMB
BALANCING MACHINES