

DWA 3500



3D HD WHEEL ALIGNMENT FOR CAR AND LIGHT TRUCK

3D-HD wheel aligner with movable camera
automatically adjustable with lift height



CEMB

DWA 3500

ADVANCED SOFTWARE

Wheelbase, track and diagonal measurements to prevent damage from accidents

Wheel diameter measurements to verify correct pressure **Single raised wheel run-out** for smaller workspaces or lifts with stairs

Measurements with 2 targets for long vehicles **Caster angle and friction range measurements**

Audit Function: identification of driving problems, resulting from measures not contemplated in the specifications to support the regulation service

Movable cameras automatically adjustable with lift height **Quarterly updates of the data bank** for clear, rapid selection of different versions of vehicles **Frontal assistance video camera** to help get onto the lift

TARGETS

 **Compact Targets** with no electronics and batteries



CABINET

Ergonomic design and easy accessibility during maintenance operations
Industrial computer with Windows 10 and SSD memory, without moving disks more likely to break
WiFi connection for automatic software updates

STANDARD with 43" monitor PIT with double monitor (27" and 21") to ease the adjustment in pit

STANDARD: Fixed cabinet **OPTION:** (Trolley kit to move cabinet together with column)

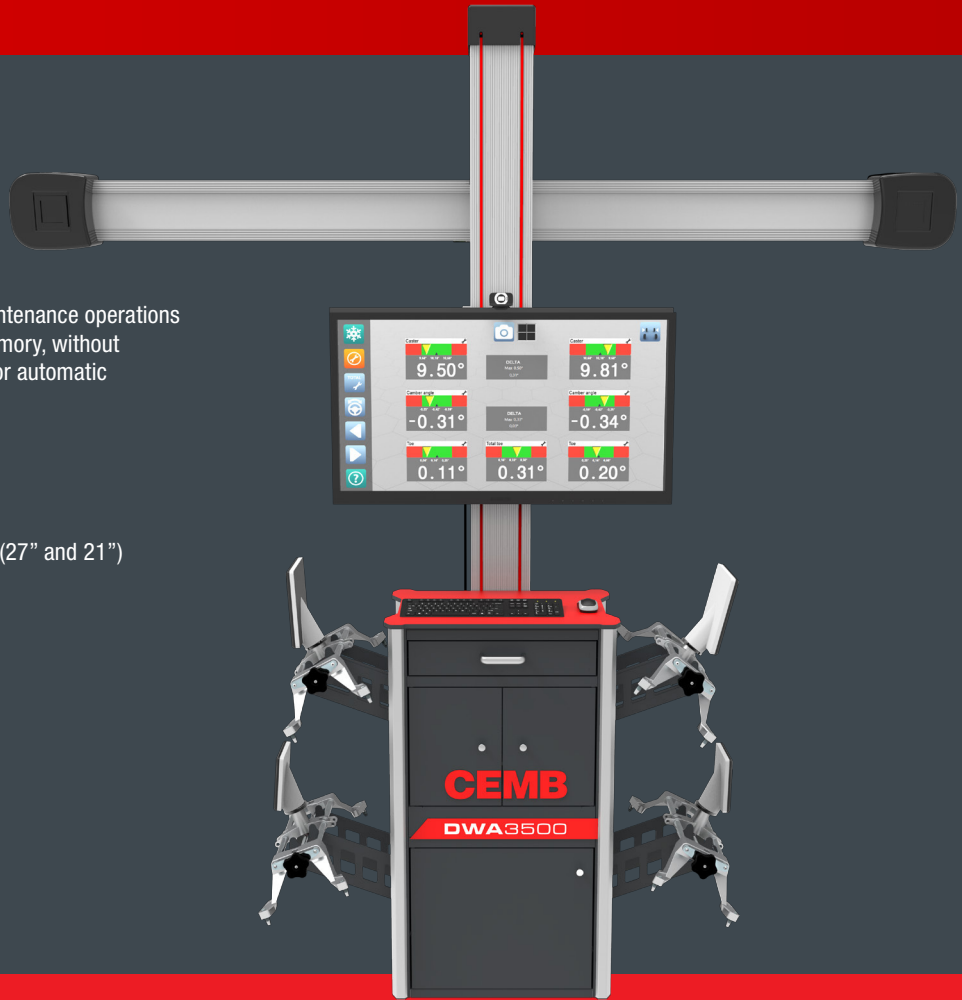

STANDARD CONFIGURATION

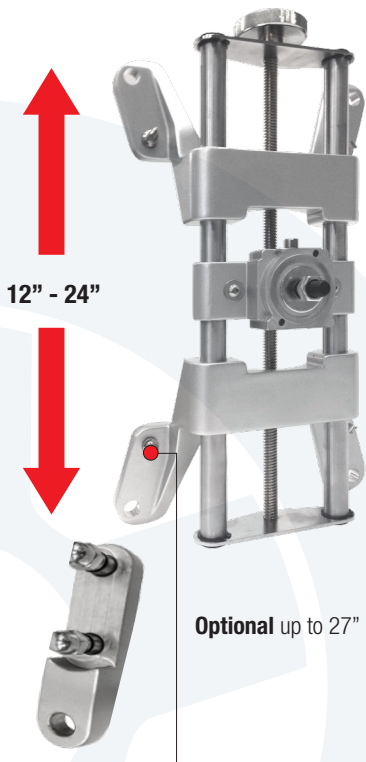

Premium turntables: capacity 1000 kg per plate, diameter 35 cm, with rubber supports



Universal grips with locking system

OPTIONAL ACCESSORIES

Automatic locking/unlocking turntables

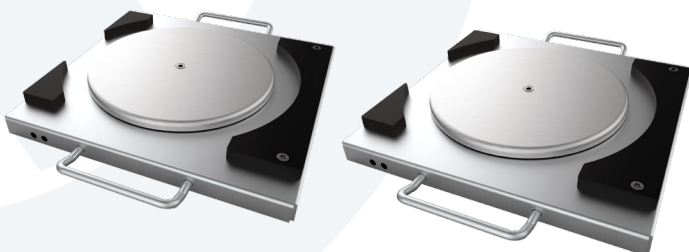

STANDARD COMPOSITION



- Cabinet
- Computer with WINDOWS 10 operating system
- 43" TFT monitor, colour printer, wifi keyboard, loudspeakers, front webcam, wifi pen drive
- Four 4-point clamps 12"-24" with universal grips and targets
- Camera support with automatic control
- Brake pedal lock, steering lock
- Wheel alignment software and database for CARS

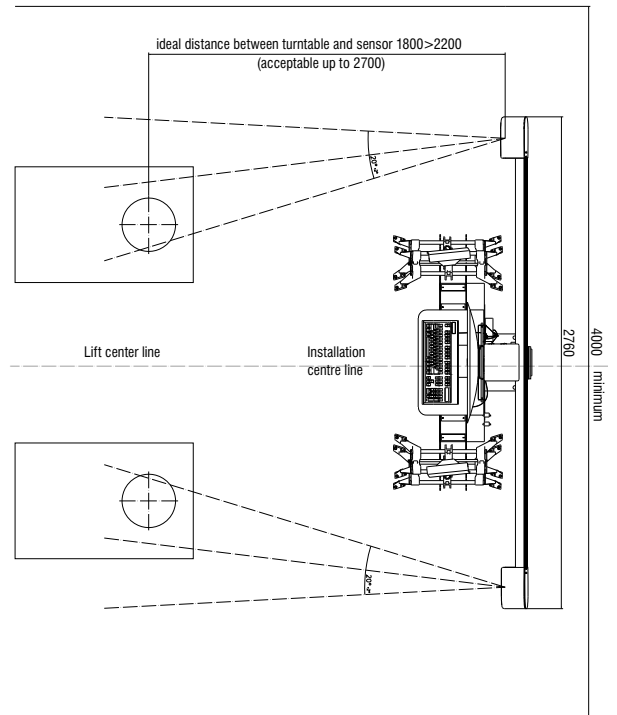
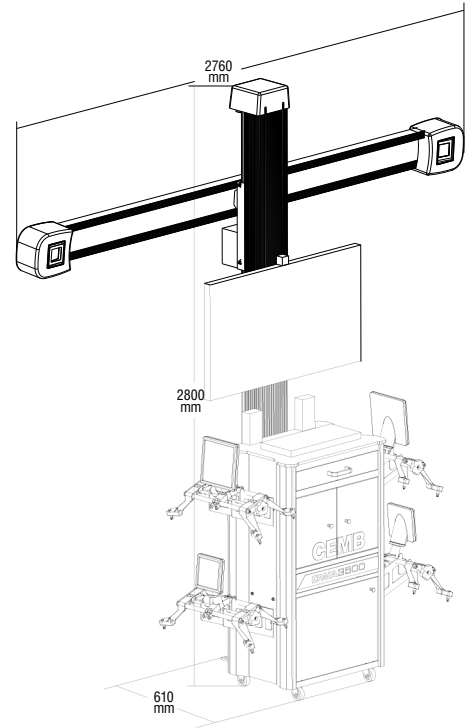

Available only in selected countries
Disponibile solo in paesi selezionati
Disponible seulement dans pays sélectionnés
Disponible sólo en los países seleccionados
Nur in ausgewählten Ländern erhältlich



Garage equipment division

CEMB USA - BL Systems Inc.
2873 Ramsey Road
Gainesville, GA 30501 - USA
Phone +001 678 717 1050
Fax +001 678 717 1056
sales@cemb-usa.com
www.cemb-USA.com