

ER 15



ENGINEERED IN ITALY
MADE FOR THE USA

SPACE-SAVING
3D WHEEL
BALANCING
MACHINE WITH
VIDEO TOUCH



CEMB
GARAGE EQUIPMENT

FR15

- **Data entry via automatic gauge** to measure the distance and diameter of rims of up to 28" with an innovative clip to hold the adhesive weight
- **Virtual Sonar** for 3D measurements of wheels that, in cases of metal rims and absence of sonar, calculates the width of the rim
- **AutoAdaptive Mode** - The new tolerance calculation system
- **New and larger 17" touch graphic interface**
- **Electromagnetic brake** for the lock of the wheel in the exact weight position
- Software programs for the professionals: **SPLIT, OPT, ALU**
- **ALU-S 3D Balancing mode** - Adhesive weights on the internal rim planes with specific counterweight position indicator
- **Correction mode with LASER line** for quick and safe positioning of the adhesive weights inside the rim and integrated LED light to illuminate the work space
- **Automatic approach** of the wheel within 15° from the point of application of the balancing weight, to allow the operator to position it correctly, with minimum movement
- **Low balancing speed**
- Latest generation **VDD Virtual Direct Drive** - Super-fast and extremely accurate measuring system



VIRTUAL

Virtual Sonar INNOVATIVE 3D SOFTWARE THAT CALCULATES RIM WIDTH

- After acquiring the position of the first plane of correction, the new software **Virtual Sonar** calculates the width of the rim, identifying a possible range of external correction planes.
- During the measurement spin, **Virtual Sonar** verifies that it is possible to fall within the tolerance with the correction indicated on all possible external planes.
- If there is even one possible plane for which the required correction does not allow the residual unbalance to fall within the tolerance range (calculated with AutoAdaptive software), the machine will request manual entry of the rim width in mm.

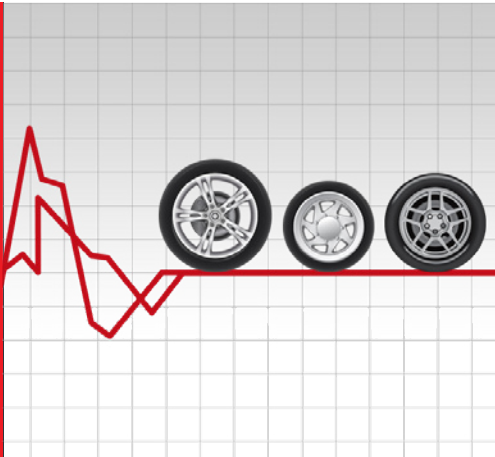

AutoAdaptive

AutoAdaptive Mode THE NEW TOLERANCE CALCULATION SYSTEM

- The innovative tolerance calculation system **AutoAdaptive Mode** is based on the evaluation of the residual imbalance limit value corresponding to an acceptable perceived vibration. For each wheel that is balanced, the software **AutoAdaptive Mode** detects weight and dimensions and calculates the tolerance value that will cancel any vibration perceived on the steering wheel. **AutoAdaptive Mode** grants the highest comfort when driving and saves balancing time.

- **NEW 17" TOUCH GRAPHIC INTERFACE**

larger and improved, makes the interaction with the system even more accurate and satisfying

- **COMPACT** with small dimensions to fit anywhere, even in workshops with limited space

- **TECHNOLOGICAL** standard equipped with advanced technical features such as Virtual sonar, Autoadaptive, electromagnetic brake and Automatic Approach

CEMB
INNOVATIONS



AUTOMATIC APPROACH



Automatic Approach

AUTOMATIC APPROACH TO THE CORRECTION POSITION

Once the measuring launch is completed, the wheel automatically stops around 15° from the exact point of application of the counterweight, allowing the operator to position it correctly with a little movement. After the first plane correction, pressing start/repositioning button the wheel will be repositioned around the second correction point.

STANDARD ACCESSORIES

In 1952 Cemb created the cone adapters for balancing machines and since then the company continued developing and producing high precision centering systems for any type of wheel. **Cemb does not recommend the use of non-original adapters on its balancing machines.**

UC20/2 GL40

Standard equipment UC20/2 GL40 composed of quick locknut GL40 and 3 cones kit



LOCKNUT KIT - 41FF83146

Locknut Kit (quick locknut GL40, with sleeve and ring)



3 CONES KIT - 41FF034416

Ø 45÷110 mm, pincer-hammer and 60 g. counterweight



46FC77653

Width gauge

Wheels with special dimensions, geometry and centring may require the use of special flanges that CEMB supplies as an option, to better meet the needs of the market. **For more information see the complete brochure on the web site: www.cemb.com**



Zero Weight /Easy Weight Lifts

OPTIONS TO REDUCE ANY EFFORT

- **PERFECT CENTERING** for a more accurate balancing
- **"ZERO WEIGHT" EFFECT** The patented system detects the weight of the wheel and cancels it automatically
- **ERGONOMICS** to minimize the effort for the operator
- **UNIVERSALS** Applicables to any CEMB balancing machine

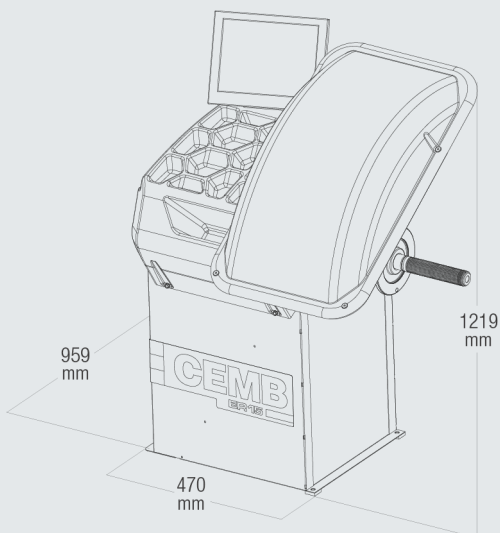

Power Supply

Wheel Clamping Type

Max Rim Diameter

Max Rim Width

Max Tire Diameter

Max Wheel Weight

Machine Weight

110V, 1ph

Manual

30" (765 mm)

20" (510 mm)

36" (915 mm)

165 lbs. (75 kg)

145 lbs. (110 kg)



CEMB
BALANCING MACHINES



CEMB USA - BL Systems Inc.

2873 Ramsey Road

Gainesville, GA 30501 - USA

Phone +001 678 717 1050

Fax +001 678 717 1056

sales@cemb-usa.com

www.cemb-USA.com