











# ER75 TD

*spotter*

RELIABILITY  
FEATURES  
DESIGN



 SPOTTER	 OPB	 AutoAdaptive	 HubMatch	 AUT	 AUT
 LA sonar	 BRAKE	 PNEUMATIC	 TOUCH	 GP	

# CEMB



# ER75 TD

## FROM CEMB EXPERIENCE

- ER75 TD balancer is the result of CEMB consolidated experience in the manufacturing of high technology garage and industrial balancers since 1946. Development and cooperation with the most important car and tyre manufacturers guarantee to the professionals in the garage equipment field:
- Reliability
- Easy and quick use
- Accuracy
- Completely configurable
- Reduced cycle time!

## INNOVATIVE DESIGN:

# ERGOFAST

- With ER75TD, CEMB widens its range of products **ERGOFAST**, maintaining the concepts of ergonomics and practicality together with the original design
- WBA Wheel Best Access** Wide space to work inside the rim
- Innovative touch screen
- Ergonomic tool positioning **CLOSE AT HAND!**

## CORE OF TECHNOLOGY

- Laser Spotter** - Greatest accuracy in the weights positioning during the correction
- OPB One Plane Balancing** - Correction of both static and dynamic unbalance on one plane at once and with only one weight
- AutoAdaptive Mode** - The new tolerance calculation system
- Sonar LA** for automatic measurement of the wheel width **CEMB PATENT**
- ALU-S Balancing mode** - Adhesive weights on the internal rim planes with specific counterweight position indicator
- Led light** to illuminate the working space inside the rim
- Sonar EMS** (option) - 1st Harmonic and Peak to Peak Automatic and quick eccentricity measurement during the normal balancing cycle
- HubMatch** - During the measuring cycle, the wheel's "maximum eccentricity point" is detected and displayed on monitor, therefore allowing for its reduction during the re-mounting of wheel on vehicle (only with EMS Sonar)
- Tire Set** - The software indicates the best wheel positioning on the vehicle to get the best ride (conicity) and to minimize wheel vibrations (eccentricity) (option available only with EMS sonar)
- ER75TD - Pneumatic wheel locking** **CEMB PATENT**  
Floor to floor time reduction / Extremely easy and quick to use / Very accurate wheel centering
- Automatic rotation and locking** of the wheel in weight position
- Extended gauge** for diameter and distance measurement of rims up to 28"
- VDD Virtual Direct Drive** - Very quick and maintenance free measurement system **CEMB PATENT**



### PNEUMATIC LOCKING



### SONAR LA



## Laser Spotter

**PERFECT BALANCING IN JUST ONE SPIN**

- Greatest accuracy in weights positioning through laser spotter.
- Preview of the exact weight positioning spot visible already during the wheel dimensions acquisition phase.
- During the correction, the **LASER SPOTTER** pinpoints the exact position for stick-on weights application inside the rim. Thanks to the electric brake - which locks the wheel into the exact angular position of the unbalance - you avoid possible errors during the weight application making the balancing process faster, simpler and more precise.
- In static balancing mode, **LASER SPOTTER** detects the exact static weight location, in order to minimize the residual unbalance on the external planes.



## One Plane Balancing

**WHERE INNOVATION MEETS SIMPLICITY**

- **OPB** (One Plane Balancing) eliminates both static and dynamic unbalance with a single counterweight, indicating the exact position to apply the weight inside the rim. The balancer automatically detects if it is possible to correct both unbalances with only one weight and activates **OPB program**. A real revolution in wheel balancing. **OPB** saves you time while maximizing your productivity.

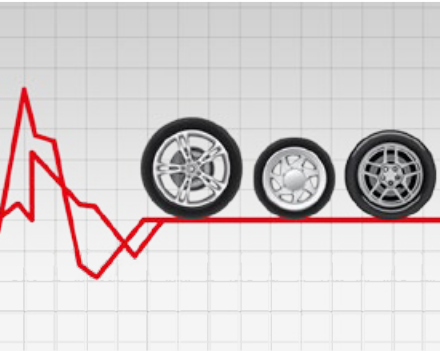

## AutoAdaptive Mode

**THE NEW TOLERANCE CALCULATION SYSTEM**

- The innovative tolerance calculation system **AutoAdaptive Mode** is based on the evaluation of the residual imbalance limit value corresponding to an acceptable perceived vibration. For each wheel that is balanced, the software **AutoAdaptive Mode** detects weight and dimensions and calculates the tolerance value that will cancel any vibration perceived on the steering wheel. **AutoAdaptive Mode** grants the highest comfort when driving, and together with **OPB program**, saves balancing time.

In 1952 Cemb created the cone adapters for balancing machines and since then the company continued developing and producing high precision centering systems for any type of wheel. **Cemb does not recommend the use of non-original adapters on its balancing machines.**

### STANDARD ACCESSORIES

Standard equipment UC20/SE2 composed of: SE kit, 3 cones Kit and WDC gauge



**PNEUMATIC LOCKING**

**41FF034417**  
**SE Kit** (ring, quick locking sleeve SE2, SE spacer)



**41FF034416**  
**3 cones kit** Ø 45÷110 mm, pincer-hammer and 60 g. counterweight



**46FC77653**  
**Width gauge**



### OPTIONAL ACCESSORIES - Especially designed for car manufacturers



#### Pro Kit (PROKIT)



Pin Plate Adaptor  
Manual - 41FFA6478 Pneumatic - 41FFA5298



2-Piece Truck Cone Kit  
41FFB6174



40FF52417

#### Pro Plus Kit (PROPLUS)



Pin Plate Adaptor  
Manual - 41FFA6478 Pneumatic - 41FFA5298



40FF43745



40FF52417



Pneumatic Wheel Lift  
46FLB5170



Accessory Rack  
41FF03151

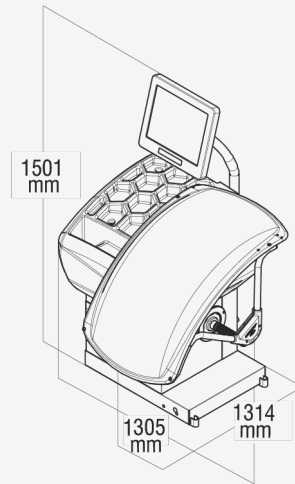

Power supply	220V, 1ph, (Air for ER75)
Wheel Clamping Type	Pneumatic
Max. Rim Diameter	30" (765 mm)
Max. Rim Width:	20" (510 mm)
Max. Tire Diameter:	42" (1067 mm)
Max. Wheel Weight:	165 lbs. (75 kg)
Machine Weight:	264 lbs. (120 kg)



## Zero Weight Lift

OPTION TO REDUCE ANY EFFORT

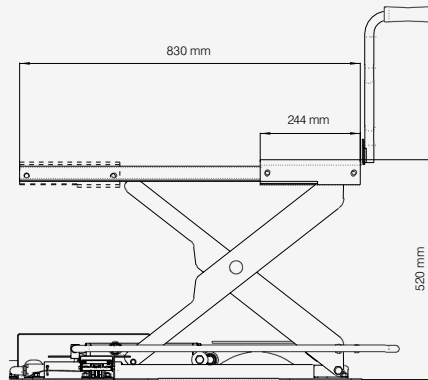

For more information see the complete brochure on the web site [www.cemb-usa.com](http://www.cemb-usa.com)

Wheel loading and removal without effort or adjustment

- **PERFECT CENTERING** Wheel automatic lifting Ideal centering and more accurate balancing
- **QUICK** Quicker than any other traditional lift A single pedal controls the whole working cycle
- **AUTOMATIC** Electronic system with PLC
- **UNIVERSAL** Applicable to any CEMB balancing machine



# CEMB

BALANCING MACHINES

CEMB S.p.A.  
2873 Ramsey Rd.  
Gainesville, Ga. 30501  
[www.cemb-usa.com](http://www.cemb-usa.com)



Garage equipment division  
CEMB - U.S.A.  
Plant and Training Center  
Phone (678) 883-7909  
[garage@cemb-usa.com](mailto:garage@cemb-usa.com)

