

ER95 PLUS

FASTER THAN EVER

THE **FASTEST**
FULLY AUTOMATIC
BALANCING
MACHINE IN THE
WORLD



ER95PLUS

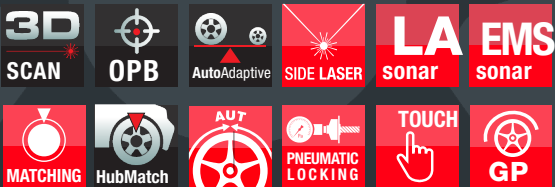

CEMB

GARAGE EQUIPMENT



ENGINEERED IN ITALY
MADE FOR THE USA

ER95 PLUS

- **3D Laser Scan** - Extraordinary accuracy and speed in 3D acquisition of wheel sizes with exact positioning of adhesive weights
- **Side Laser** - Line laser indicator on the upper part of the wheel to ease the application of clip-on weights in the exact position
- **OPB One Plane Balancing** - Correction of both static and dynamic unbalance on one plane at once and with only one weight
- **AutoAdaptive Mode** - The new tolerance calculation system
- **Sonar LA** for automatic measurement of the wheel width **CEMB PATENT**
- **EMS sonar** to measure the wheel eccentricity; through high precision sensors, it is able to detect variations in the distance between wheel center and its external edges during rotation, allowing them to be corrected those irregularities that would make the vehicle less safe
- **Direct Matching** - Visualization of the best possible matching to reduce eccentricity
- **HubMatch®** - During the measuring cycle, the wheel's "maximum eccentricity point" is detected and displayed on monitor, therefore allowing for its reduction during the re-mounting of wheel on vehicle
- **Tire Set** - The software indicates the best wheel positioning on the vehicle to get the best ride (conicity) and to minimize wheel vibrations (eccentricity)
- **ALU-S Balancing mode** - Adhesive weights on the internal rim planes with specific counterweight position indicator (position repeater)
- **Automatic positioning speed doubled** and instantaneous locking of the wheel at the point of weights application
- **Led light** to illuminate the working space inside the rim
- **Pneumatic wheel locking CEMB PATENT** - Floor to floor time reduction / Extremely easy and quick to use and very accurate wheel centering

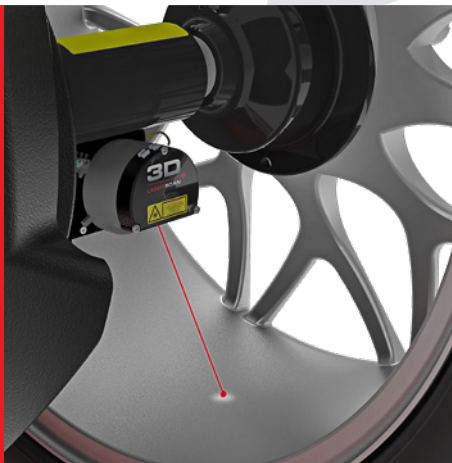

**3D
SCAN**

3D Laser Scan

EXTREME MEASURING PRECISION AND FASTER WEIGHT APPLICATION

- Touchless wheel distance and diameter measuring system which, combined with the LA sonar for width measurement, detects with 3D precision the dimensions of any profile, even the most complex; no intervention of the operator.
- Advanced technology that speeds up the dimensions reading process without penalizing reliability and precision.
- Brighter laser pointer that grants an extreme accuracy during correction thanks to a clear indication of the application point for stick-on weights.
- Greatest robustness for a long lasting usage. No moving parts are exposed, risks of damages are reduced.
- Easy maintenance.

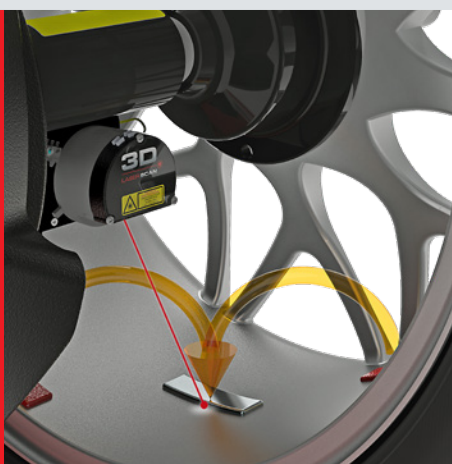

One Plane Balancing

OPB WHERE INNOVATION MEETS SIMPLICITY

- **OPB** (One Plane Balancing), eliminates both static and dynamic unbalance with a single counterweight, indicating the exact position to apply the weight inside the rim. The balancer automatically detects if it is possible to correct both unbalances with only one weight and activates **OPB** program.
A real revolution in wheel balancing. **OPB** saves you time while maximizing your productivity.

FASTER THAN EVER

6.4 Seconds

IN A SINGLE MEASUREMENT CYCLE:

- Automatic acquisition of wheel dimensions and correction planes
- Unbalance measurement
- Rim runout measurement
- One Plane Balancing
- Tire runout measurement
- Direct matching
- Hubmatch®



CEMB

INNOVATIONS

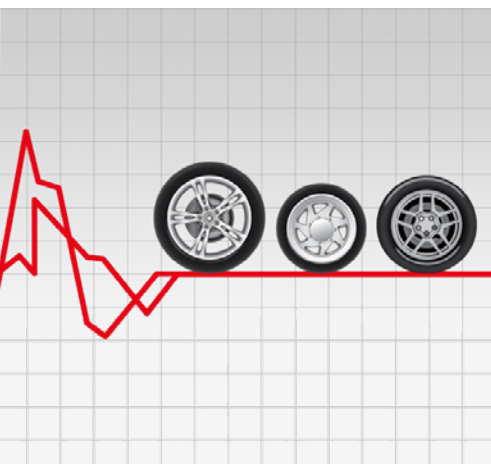

AutoAdaptive

AutoAdaptive Mode

THE NEW TOLERANCE CALCULATION SYSTEM

- The innovative tolerance calculation system **AutoAdaptive Mode** is based on the evaluation of the residual imbalance limit value corresponding to an acceptable perceived vibration. For each wheel that is balanced, the software AutoAdaptive Mode detects weight and dimensions and calculates the tolerance value that will cancel any vibration perceived on the steering wheel. AutoAdaptive Mode grants the highest comfort when driving, and together with **OPB** program, saves balancing time.

STANDARD ACCESSORIES

In 1952 Cemb created the cone adapters for balancing machines and since then the company continued developing and producing high precision centering systems for any type of wheel. **Cemb does not recommend the use of non-original adapters on its balancing machines.**

UC20/SE2

Composed of:
SE kit and 4 cones Kit



**PNEUMATIC
LOCKING**



SE KIT - 41FF034417

Ring, quick locking sleeve SE2, SE spacer



4 CONES KIT - 41FF030594

Ø 45÷110 mm, pincer-hammer and 60 g counterweight

Wheels with special dimensions, geometry and centering may require the use of special flanges that CEMB supplies as an option, to better meet the needs of the market. **For more information see the complete brochure on the web site: www.cemb-usa.com**



OPTIONAL ACCESSORIES



Zero Weight /Easy Weight Lifts

OPTIONS TO REDUCE ANY EFFORT

- **PERFECT CENTERING** for a more accurate balancing
- **"ZERO WEIGHT" EFFECT** The patented system detects the weight of the wheel and cancels it automatically
- **ERGONOMICS** to minimize the effort for the operator
- **UNIVERSALS** Applicable to any CEMB balancing machine

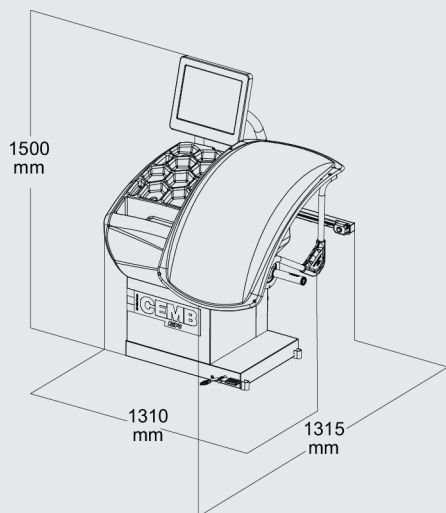

DIMENSIONS

Power Supply:	230V/1ph/50 Hz
Wheel Clamping Type:	Pneumatic 120 psi
Max Tire Diameter	42" (1016)
Max. Wheel Diameter:	30" (765 mm)
Max. Wheel Width:	20" (510 mm)
Max. Wheel Weight:	165lbs. (75 kg)
Balancing Speed:	100 rpm
Machine Weight:	485 lbs. (220 kg)



CEMB

BALANCING MACHINES

www.CEMB-USA.com

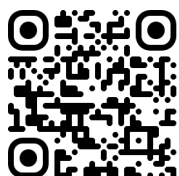

Garage equipment division
CEMB - USA
Plant and Training Center
Phone +1 (678) 717-1050

CEMB USA - BL Systems Inc.
2873 Ramsey Road
Gainesville, GA 30501 - USA
sales@cemb-usa.com

All the data and features mentioned in this catalogue are purely for information and do not constitute any commitment on the part of our company, which reserves the right to make any and all alterations it may consider suitable without notice.