

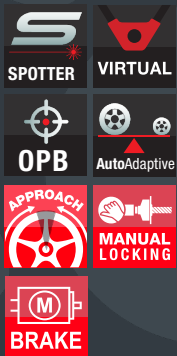

ENGINEERED IN ITALY
MADE FOR THE USA

MOVE!

USE IT WHEREVER YOU CHOOSE!



CEMB

GARAGE EQUIPMENT

MOVE!

USE IT WHEREVER YOU CHOOSE!

UNIQUE AND REVOLUTIONARY DATA INPUT SYSTEM BASED ON 2-HIT TECHNOLOGY

By manually moving the wheel, the **LASER SPOTTER**, combined with a line laser (**LASER MATCHING**), moves on the rim to measure its dimensions without using the gauge anymore. The same laser then indicates the exact point where to apply the correction weights, making the balancing process even more efficient. The confirmation and transmission of the data acquired by the two lasers to the software occurs by pressing a pushbutton.

ROTATING INTERFACE with rear knob for locking in position or setting intermediate positions as required; 90 degree rotation makes the weight carrier fully accessible.

- **Virtual Sonar** for 3D measurements of wheels that, in cases of metal rims and absence of sonar, calculates the width of the rim
 - **OPB One Plane Balancing** - Correction of both static and dynamic unbalance on one plane at once and with only one weight
 - **AutoAdaptive Mode** - The new tolerance calculation system
 - **Electromagnetic brake** for the lock of the wheel in the exact weight position
 - **Automatic approach** of the wheel within 15° from the point of application of the balancing weight, to allow the operator to position it correctly, with minimum movement
 - Software programs for the professionals: **SPLIT, OPT, ALU**
 - **ALU-S 3D Balancing mode** - Adhesive weights on the internal rim planes with specific counterweight position indicator
-
- **Led light** to illuminate the working space inside the rim



Virtual Sonar

INNOVATIVE 3D SOFTWARE THAT CALCULATES RIM WIDTH

- After acquiring the position of the first plane of correction, the new software **Virtual Sonar** calculates the width of the rim, identifying a possible range of external correction planes.
- During the measurement spin, **Virtual Sonar** verifies that it is possible to fall within the tolerance with the correction indicated on all possible external planes.
- If there is even one possible plane for which the required correction does not allow the residual unbalance to fall within the tolerance range (calculated with AutoAdaptive software), the machine will request manual entry of the rim width in mm.



One Plane Balancing

WHERE INNOVATION MEETS SIMPLICITY

- **OPB** (One Plane Balancing), eliminates both static and dynamic unbalance with a single counterweight, indicating the exact position to apply the weight inside the rim. The balancer automatically detects if it is possible to correct both unbalances with only one weight and activates **OPB program**. A real revolution in wheel balancing. **OPB** saves you time while maximizing your productivity.

Cemb MOVE! is the new fully-automatic balancing machine designed for mobile service, but perfect also for workshops where space is limited thanks to its exceptional compact size. Its extraordinary versatility makes **MOVE!** usable anywhere, with the same performance as high-end models.

MOVE!

**LIGHT, ERGONOMIC, FUNCTIONAL, VERSATILE.
SELECT YOUR INSTALLATION CONFIGURATION:**

VAN



■ **CONFIGURATION**

Ideal for mobile service, for easy installation on a van

WORKSHOP

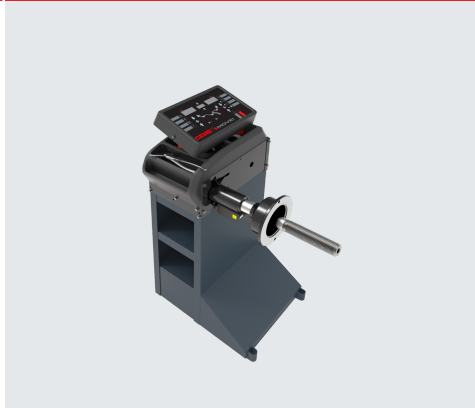

■ **CONFIGURATION**

Ideal for installation in workshops with limited space

CEMB INNOVATIONS

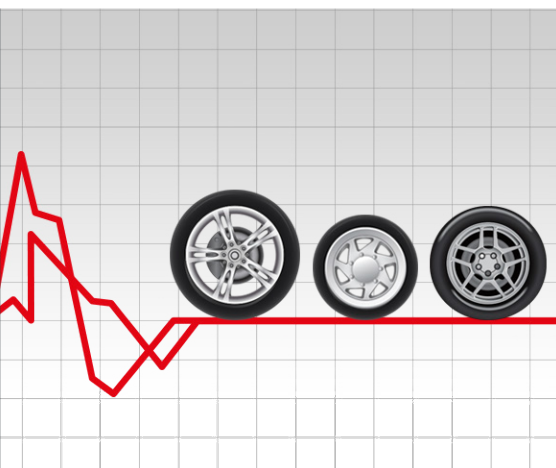

AutoAdaptive Mode

THE NEW TOLERANCE CALCULATION SYSTEM

- The innovative tolerance calculation system **AutoAdaptive Mode** is based on the evaluation of the residual imbalance limit value corresponding to an acceptable perceived vibration. For each wheel that is balanced, the software **AutoAdaptive Mode** detects weight and dimensions and calculates the tolerance value that will cancel any vibration perceived on the steering wheel. **AutoAdaptive Mode** grants the highest comfort when driving and saves balancing time.

AUTOMATIC APPROACH



Automatic Approach

AUTOMATIC APPROACH TO THE CORRECTION POSITION

- Once the measuring launch is completed, the wheel automatically stops around 15° from the exact point of application of the counterweight, allowing the operator to position it correctly with a little movement. After the first plane correction, pressing start/repositioning button the wheel will be repositioned around the second correction point.

MOTO WHEELS BALANCING

OPTIONAL BASEPLATE



MOTO CORRECTION MODE:

standard feature that turns auto correction and all related functions off when the button is pressed, automatically setting the balancing program that is most suitable for motorcycle wheels.



OPTIMIZED SPACE!

Compared to a standard balancing machine:

- 3 times more compact
- up to 4 times lighter

MAXIMUM DIMENSIONS:

36.5 x 17.75 x 15 in. (with interface open at 90°) 30 x 17.75 x 15 in. (with closed interface)

WEIGHTS:

The device alone weighs less than 65 lbs. The optional baseplate has an additional weight of approx. 35 lbs.



Additional wheel kit on request

STANDARD ACCESSORIES

In 1952 Cemb created the cone adapters for balancing machines and since then the company continued developing and producing high precision centering systems for any type of wheel. **Cemb does not recommend the use of non-original adapters on its balancing machines.**

UC20/2

Standard equipment UC20/2 GLM40 composed of quick locknut with handwheel GLM40 and 3 cones kit



41FF034431

Locknut Kit (quick locknut with handwheel GLM40, sleeve and ring, 3 cones kit Ø 45-110 mm, pincer-hammer and 60 g. counterweight)

46FC77653
Width gauge

Wheels with special dimensions, geometry and centering may require the use of special flanges that CEMB supplies as an option, to better meet the needs of the market. **For more information see the complete brochure on the web site: www.cemb-usa.com**

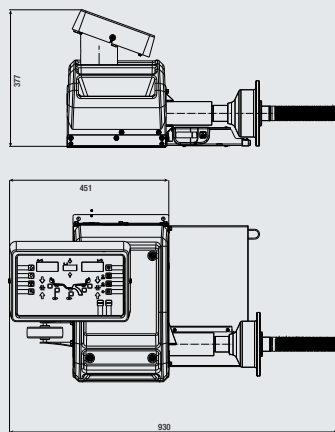
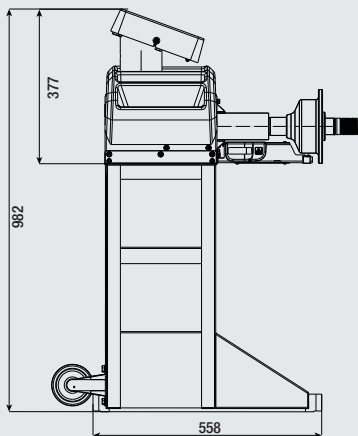

Power Supply	110V, 1ph
Wheel Clamping Type	Manual
Max. Rim Diameter	30" (765 mm)
Max Rim Width	20" (510 mm)
Max Tire Diameter	42" (1067 mm)
Max Wheel Weight	165 lbs. (75 kg)
Machine Weight	66 lbs. (30 kg)



CEMB USA - BL Systems Inc.
2873 Ramsey Road
Gainesville, GA 30501 - USA
Phone 678-717-1050
Fax +001 678 717 1056
sales@cemb-usa.com
www.cemb-usa.com