

SM615

bike

**MOTORCYCLE
TIRE CHANGER**



CEMB
GARAGE EQUIPMENT

SM615bike



- Semi-automatic tyre changer with **swing arm**, vertical working arm with lever lock, side positioning of the tool with respect to the rim by means of a knob and **vertical working arm with spring return**. Fastening of the horizontal arm on the post has been designed to allow operating on wheels with rim size from 3.6 to 22 inch (typical of motorcycles, karts, ATV wheels and hobby and gardening machines).

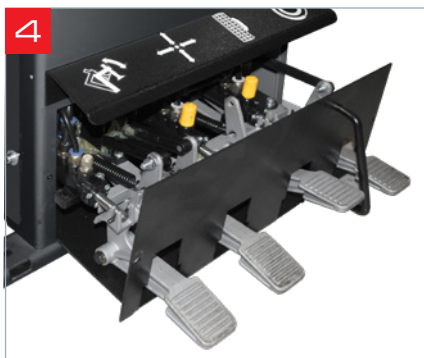

- Body with **extractable pedal** unit to facilitate technical service, **robust reduction** unit, standard CE-certified inflation pressure limiter with provision for gun connection.



Semi-automatic tire changer with horizontal moving arm, suitable for motorcycle wheels with a rim size from 3.6" to 22".

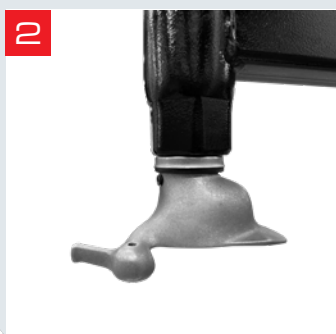

■ **Mounting head** for motorcycle wheels.



■ **Self-centring plate** with 3.6"- 22" locking capacity.

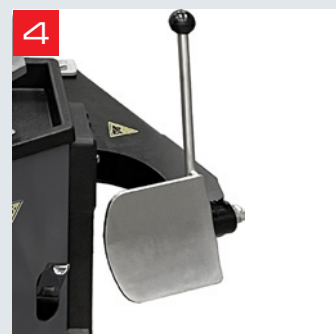

■ **Bead breaker** for motorcycle wheels with **double-acting cylinder** and **fixed blade**.

STANDARD EQUIPMENT

The machine is supplied standard with plastic protections for mounting head and for bead lifter lever to operate correctly on alloy rims.

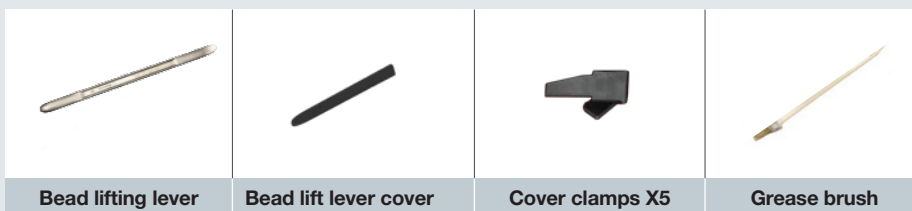

Bead lifting lever

Bead lift lever cover

Cover clamps X5

Grease brush

SM1615bike

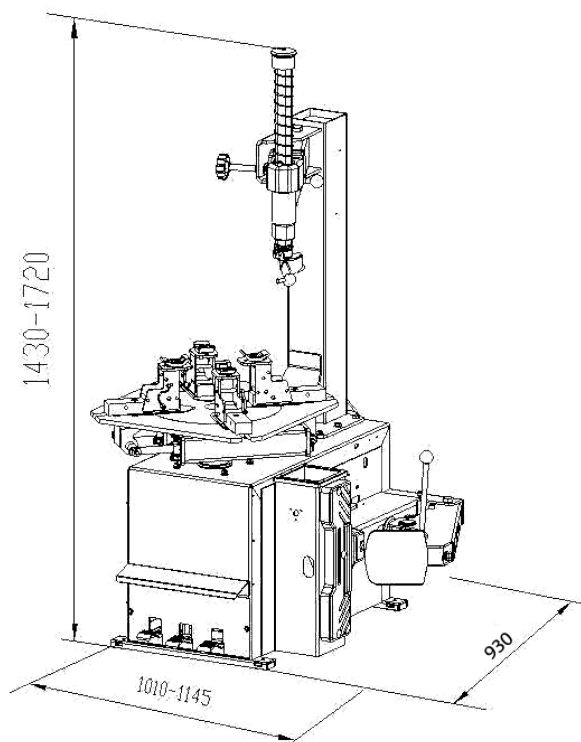

Power Supply	110V, 1ph
Air Pressure	145 psi
Clamping Capacity	3.6"-22"
Max. Wheel Diameter	39.5" (1000 mm)
Max. Wheel Width	10" (270 mm)
Turn Table Speed	7 rpm
Machine Weight:	507 lbs (230 Kg)



CEMB
BALANCING MACHINES



Garage equipment division
www.cemb-USA.com