

# SMT 56



ENGINEERED IN ITALY  
MADE FOR THE USA

**NEW**

SEMI-AUTOMATIC  
TRUCK TIRE  
CHANGER

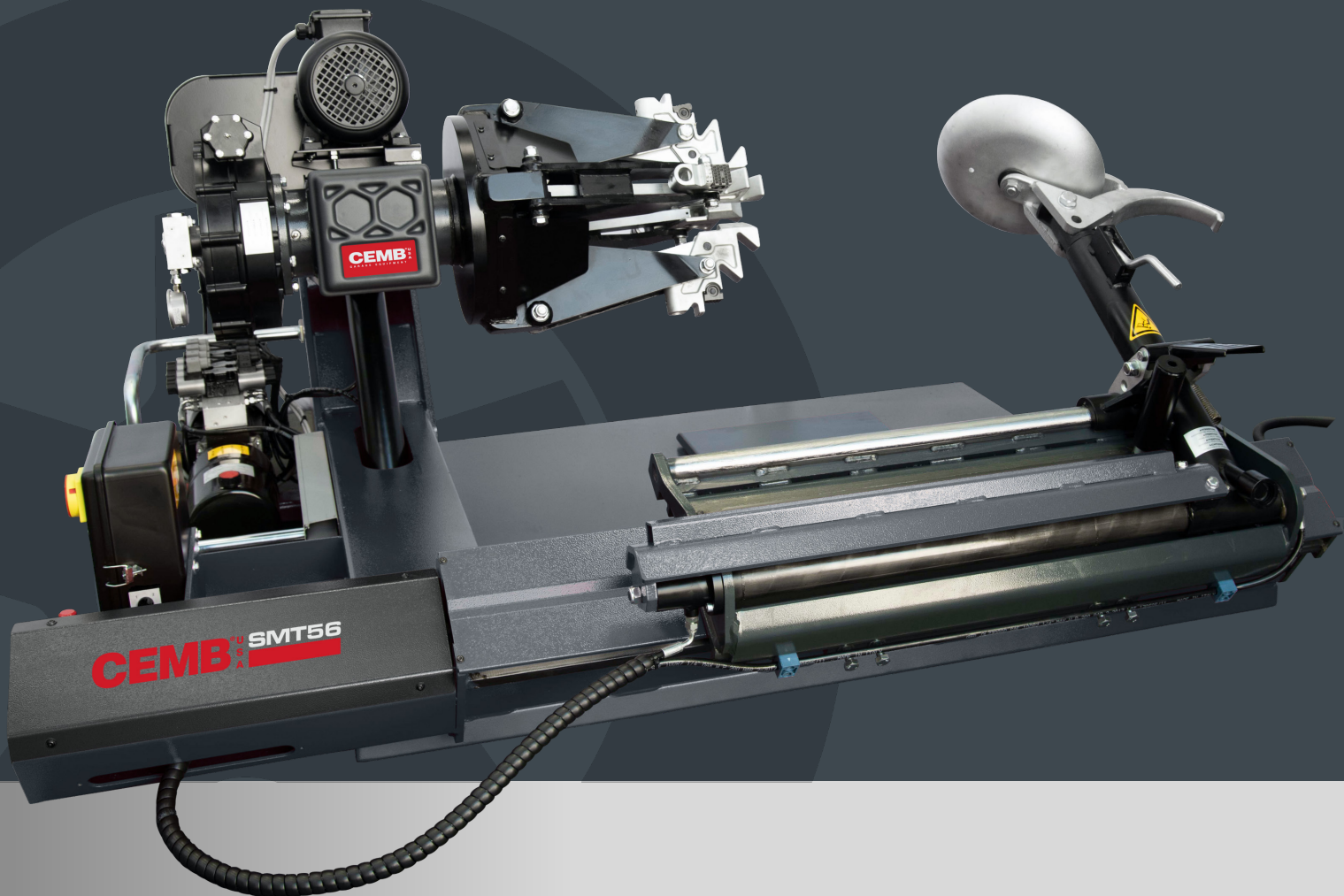

# CEMB

# SMT56

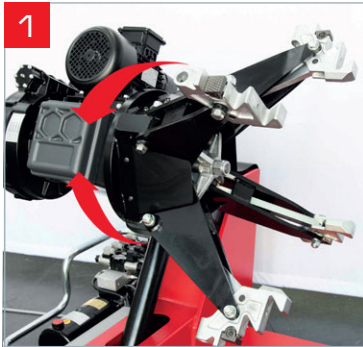

- **SELF-CENTERING CHUCK:** The hydraulic chuck has working capacity from 14" to 42" and its clamping capacity can be also extended till 56" using the optional extensions. It performs a 2-speed rotation in both directions. The special clamp profile with 5 clamping points allows also several clamping solutions.

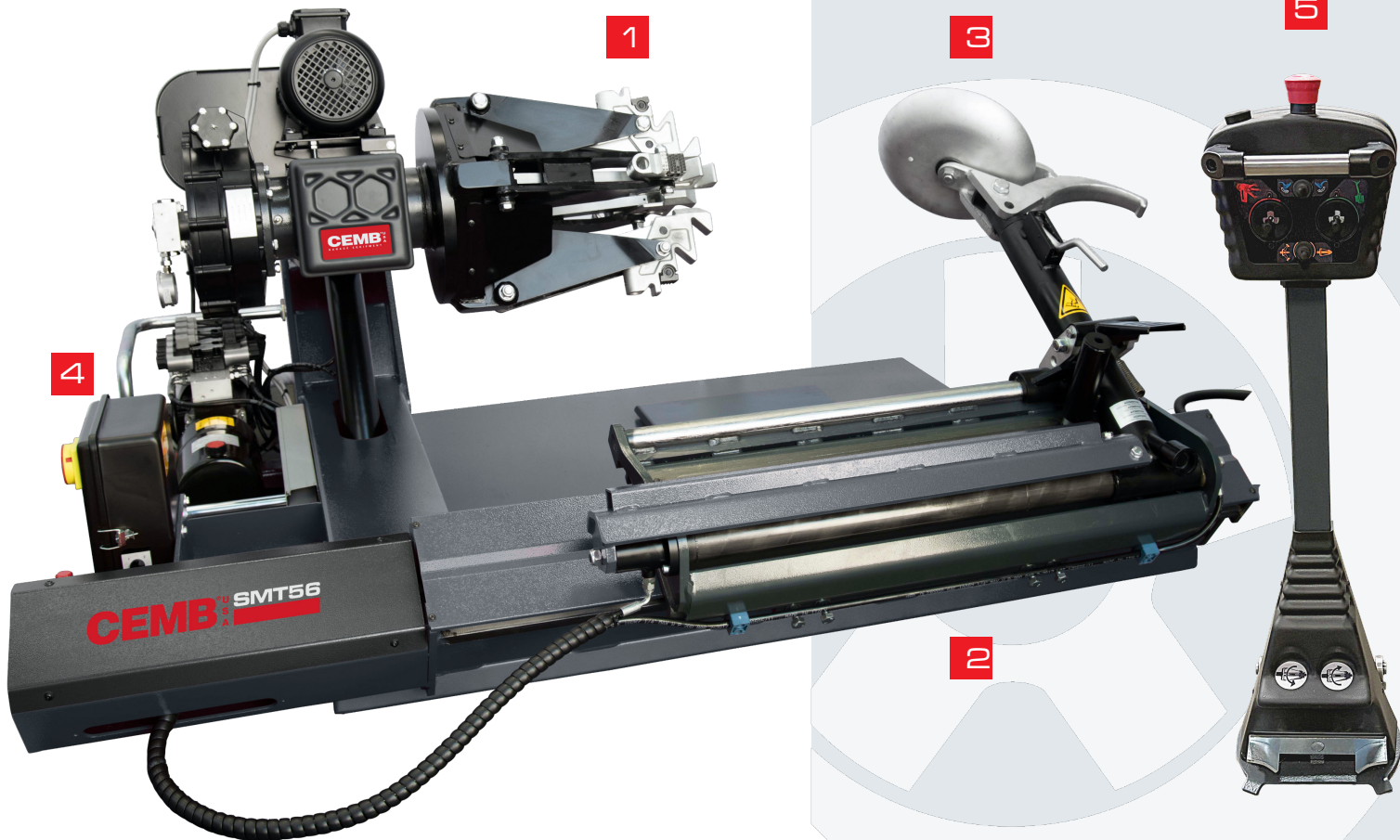

- **TOOL-HOLDER CARRIAGE:** Automatic translational movement of the tool-holder carriage for both version. Automatic tool arm movement (translational) for SMT56A and manual for version SMT56.



Universal electro-hydraulic truck tire changer designed for tubeless or inner tube tires of trucks, buses, tractors and earth moving machines with a maximum diameter of 2300 mm and a maximum width of **45" for SMT56**. Conceived for **intensive and professional purposes**, the self-centering chuck locks grooved and split ring rims from 14" to 42" and its working capacity can be increased up to 56" using the optional extensions.

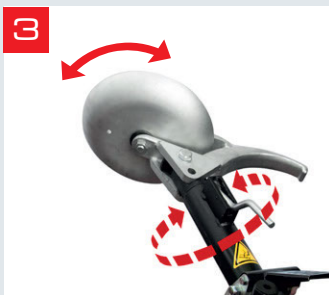

- **TOOL-HOLDER ARM:** Manual tool-holder arm lifting and tool rotation with **quick unlocking device**.



- **SAFETY DEVICES:** The SMT56 tire changer are equipped with safety devices designed to guarantee the utmost operator safety and a magneto-thermal switch to protect the electric motor.



- **CONTROL UNIT:** The machine is equipped with a low voltage portable control unit, easily movable inside the working area. The rational lay-out of control levers, buttons and pedals prevents the operator from making accidental and dangerous operational errors.

## STANDARD ACCESSORIES



**CEMB**

## TECHNICAL DATA

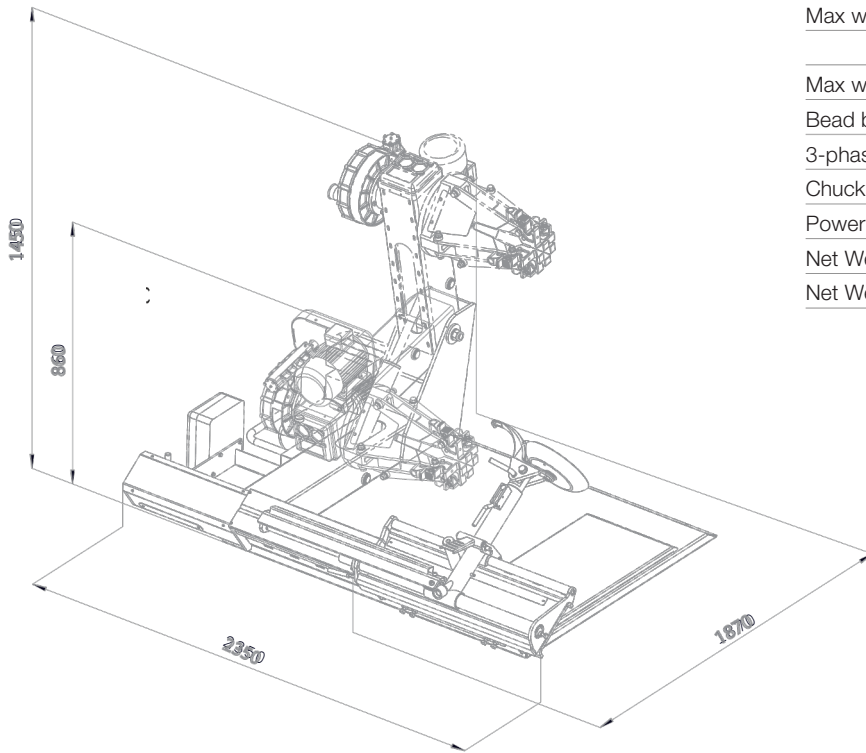

Clamping capacity	14" - 42" (56" with extensions)
Central hole minimum clamping	5" (122 mm)
Max wheel diameter	91" (2300 mm)
Max wheel width	45" (1150 mm)
Max wheel weight	4409 lbs 2000 kg
Bead breaker power in-out	25.000 N
3-phase motor	2,2 - 3 kW (3-4 Hp)
Chuck rotation speed	4,5 - 9 rpm
Power Supply	230-400V/3/50-60Hz
Net Weight SMT56A	1995 lbs 905 Kg
Net Weight SMT56	1885 lbs 855 Kg

## OPTIONAL ACCESSORIES



Set of 4 jaws for alloy rims



Plier for alloy rims



Set of 4 extensions 42"-56"



Pneumatic bead pressing device



**CEMB**  
BALANCING MACHINES



Garage equipment division  
CEMB USA - BL Systems Inc.  
2873 Ramsey Road  
Gainesville, GA 30501 - USA  
Phone +001 678 717 1050  
Fax +001 678 717 1056  
sales@cemb-usa.com  
[www.cemb-USA.com](http://www.cemb-USA.com)

All the data and features mentioned in this catalogue are purely for information and do not constitute any commitment on the part of our company, which reserves the right to make any and all alterations it may consider suitable without notice.