

CEMB

GARAGE EQUIPMENT

TORUK

LEVERLESS TYRE
CHANGER WITH
**COMBO DYNAMIC
TOOL**



NEW

1 ■ Electric center post

The center post with electric translation movement ensures maximum accuracy in wheel positioning.
Clamping range from 10" to 30".

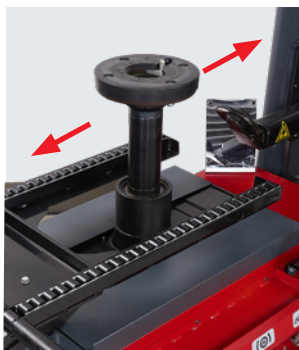

■ Automatic centering

During all working phases (bead breaking, demounting and mounting), the tool and the two rollers are all automatically aligned to the wheel just by moving the center post.

2 ■ Double roller

The lower roller, aligned with the tool, is integrated into the main frame: robust and powerful, it ensures effective pressure on the lower bead.
The upper roller places itself always tangent to the center of the rim.



3 ■ Pulse inflation Fast pedal-controlled pulse inflation with 4.2 bar (60 PSI) limitation.

4 ■ Motor with Motoinverter system

Motor controlled by a new motoinverter with progressive speed variation, granting strength and speed adapted to each tire and rim type, especially Run-Flat or UHP tires. Rotation speed from 0 to 16 rpm.



TORUK

5 ■ One hand controls

Intuitive and multi-function console to easily control all movements. Everything is close at hand to ensure perfect ergonomics. By pressing the buttons simultaneously, in a single motion, the tools are automatically moved to their rest-positions.



6 ■ Helper arm

Bead pressing arm with adjustable working height.



ON REQUEST

FACTORY ASSEMBLED

7 ■ Laser pointer

Allows easy positioning of tool and rollers.

8 ■ Wheel Lift

Keeps the rim center perfectly aligned with the self-centering device. From floor to working position in seconds. Capacity: 80 kg



WHY CHOOSE TORUK?

The new super automatic TORUK is designed for tire specialists and workshops seeking maximum productivity and meticulous care. TORUK delivers power, ergonomics and total rim protection.

ADVANTAGES

TOTAL RIM PROTECTION



- Patented Combo Dynamic Tool operating contact-free with the rim, ideal for chrome, glossy black, re-painted or delicate finishes.



+35% FASTER OPERATION

- The rapid bead-breaking system and the automatic tools reduce mounting and dismounting times.

OPERATOR ERGONOMICS AND COMFORT



- Multifunction console within easy reach, with intuitive controls and adjustable height for effortless handling.

MAXIMUM RELIABILITY AND DURABILITY



- Reinforced frame and high-strength steel components for intensive use.

FULL ADAPTABILITY



- Suitable for car, SUV and light-commercial wheels up to 30", including Run-Flat and UHP tyres.

COMBO DYNAMIC TOOL CEMB PATENTED

The new COMBO DYNAMIC TOOL integrates a bead demounting nail and a retractable mounting tool into a single system. This design makes operations faster and safer, reducing tire flexing and eliminating any risk of damage to the rim.



CONTACT-FREE DEMOUNTING

- The nail grips the tire bead and pulls it away from the rim edge. It first lifts it and then, thanks to the exclusive TORUK STEP-UP movement, the tool rises over the rim and minimizes the stress on the bead, allowing smooth demounting.

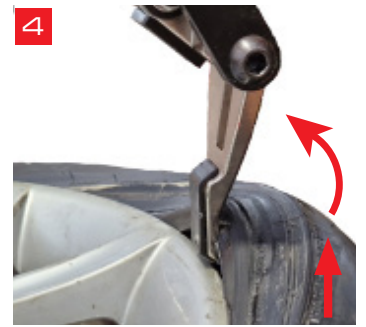

CONTACT-FREE MOUNTING

- During the mounting, the retractable mounting tool couples with the demounting nail, providing the ideal dimension for a precise tool positioning on the rim edge. The roller, built in the tool, reduces friction and allows the smooth sliding of the bead.

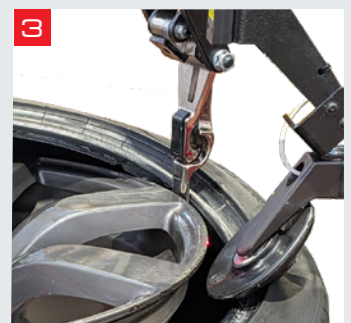
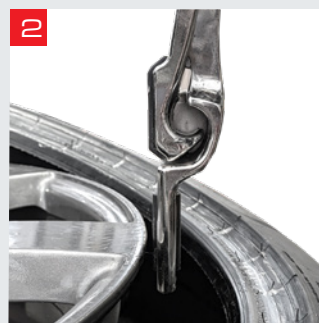

THE SOLUTION FOR ALL TYPES OF TIRES



LOW
PROFILE



TRADITIONAL



HEAVY
ASSEMBLY
up to 47"



RUN FLAT



LARGE
DIAMETER
over 20"

10" → 30"



STANDARD ACCESSORIES

46MB203209



External inflating kit for tubeless tires including air tank to be fixed on the machine (FACTORY ASSEMBLED)

46MB203403



Lower fourth arm to mount the first bead effortlessly, even on soft tires (FACTORY ASSEMBLED)



Pin to work with reversed rims, protections for locking central post, tool and pin, tool rollers and plastic lever

OPTIONAL ACCESSORIES

46MB203140



Extendable bead-pusher with draw system

46MB203554



WDK kit that includes lever, rim protection and mounting clamp RFT

46MB201373



Flange plate adapter ideal for reverse rims, plastic clad wheels and rims without center hole

46MB203529



Spacer for light truck wheels with a central hole diameter greater than 124 mm

42MB203397



Cone for securing light truck rims with central holes ranging from 122 to 174 mm

40FF61043



Special cone for precise centering of rims of SUVs, vans and light commercial vehicles with center hole 89÷ 132.5 mm

42MB202868



Rubber protection for self centering device

46MB204969



Plastic protection for demounting tool (10 units)

46MB204970



Plastic roller for mounting tool (10 units)

TECHNICAL DATA

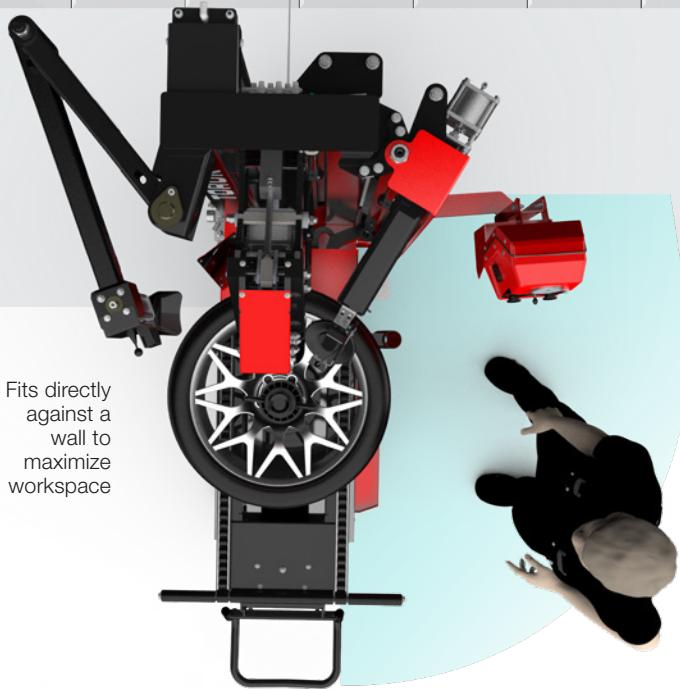

Fits directly against a wall to maximize workspace

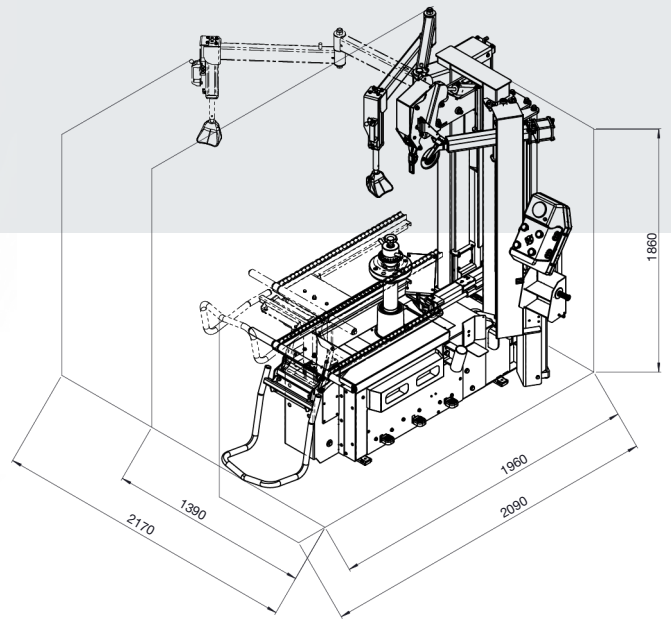

TECHNICAL DATA

Power Supply	230V 1Ph
Max wheel diameter	47" (1200 mm)
Max wheel width	15" (380 mm)
Bead breaker force	1200N
Turntable speed	16 rpm
Operating pressure	8–10 bar
machine weight	815.71 lbs (370 kg)



CEMB
BALANCING MACHINES

www.cemb-usa.com



Garage equipment division